

MJ5-i

Dehumidifying Dryer

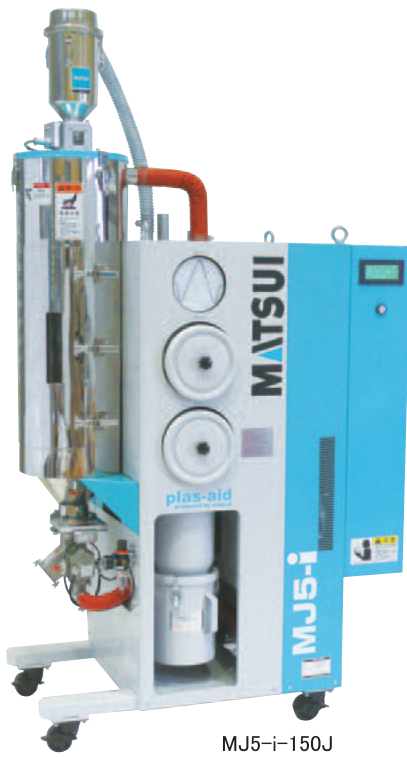

MJ5-i-150J

Outer Dimension

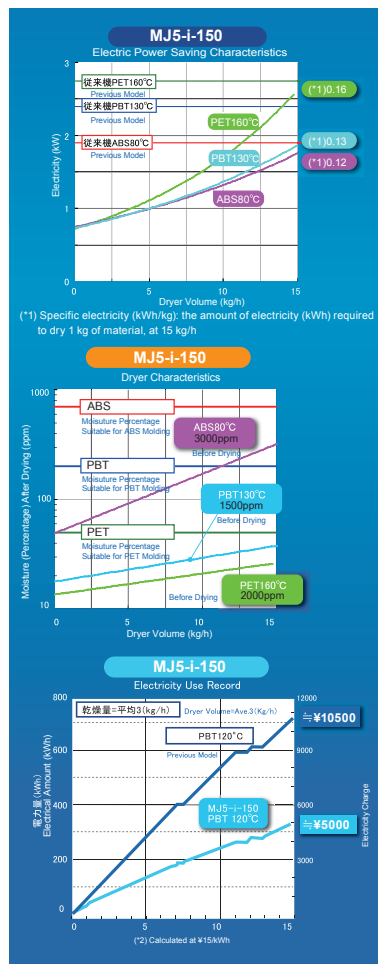
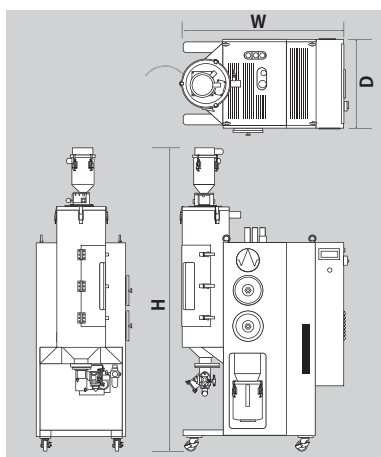

The self-control “i plas” function is built-in

Matsui has developed the “i plas” series, equipment with “i”, for intelligence, built-in. MJ5-i autonomously determines operating conditions and constantly maintains the optimal drying conditions without any intervention by the operator.

Contributes to electricity conservation!

Since MJ5-i has a low exhaust gas temperature, air conditioning load is reduced, leading to further saving of electricity.

Concept

In consideration of energy shortages occurring in Japan and worldwide, and the fact that most electricity used in molding factories is consumed by dryers, Matsui has worked towards the development of a dryer which pursues maximum energy saving performance under our mission to “achieve factor 4 in molding factories by 2020”. As a result, the MJ5-i dryer, with the self-control i plas function built-in, has been completed. The concept behind MJ5-i is “equipment with intelligence”.

Features

A maximum energy reduction of 75% has been achieved!

Conventional equipment consumes the same amount of electricity, regardless of the size of the drying load. MJ5-i has achieved energy reduction by using only the most appropriate amount of electricity according to the size of the drying load.

An industry first! Electricity is no longer wasted and running costs have been reduced by the self-control “i plas” function!

Highest Standards in the World

A Maximum Energy Reduction of 75% has been Achieved!

Maintenance can be carried out from the front

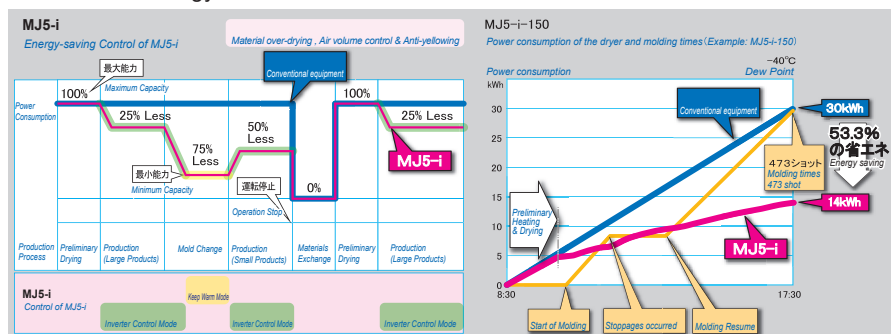

Standard specifications

Model	Load capacity (Kg.)	Drying Heater output (kW)	Dryer Blower output (kW)	Regeneration heater Capacity (kW)	Regeneration blower Capacity (W)	After-cooler Required water flow L/min.	Breaker (Amp.) 50 Hz.	Outside dimensions W x D x H (mm) x (mm) x (mm)	Weight (Kg)
MJ5-i-150-J		2.1	0.28	1.0	0.28	-	30	1125 x 618 x 2117	270
MJ5-i-350-J		2.4	0.42	2.1	0.28	-	30	1191x 618 x 2203	290
MJ5-i-650-J		5.4	1.15	3.1	0.42	-	50	1486 x 638 x 2509	400
MJ5-i-1500-J		10.8	2.55	5.8	1.15	-	100	1910 x 914x 2689	690

- Weekly Timer ● Dew-point Indicator ● 2 Direction Conveying ● Different Supply Voltage (Excluding UL/CE) ● Custom Color (Exterior Board Only) ● Alarm Output
- Alarm Indicator Light ● Signal Wire Extension ● Power Supply Wire Extension ● Jet Selector JSV-38/50 (-1500) ● Power Meter ● Color Touch Screen